

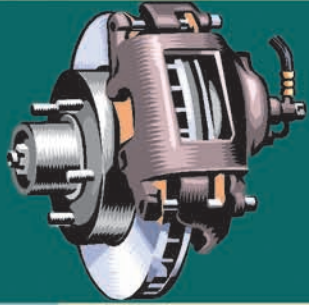

9 Reasons Why You Need a Strong Yellow Pages Program



ANALYSIS BASED ON DATA FROM SRI, NFO COMMUNICATIONS AND SIMMONS.

Auto Parts & Supplies-New

one Relevant-Yellow Pages are Used!

38% of active shoppers for new auto parts go to the heading for help. This amounts to over **17 million** customers annually.

(NFO AD:Impact, 2001).



two Ready-to-Buy

Heading users are ready-to-buy...**95%** of heading users make a purchase. No other medium can boast this high of a follow-through.

(Statistical Research, Inc., 2001)



three Decision-Impacting

69% of users make a decision based on information in the heading. **74%** of users view multiple ads when they consult the heading.

(Statistical Research, Inc., 2001)

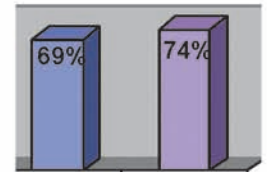

four Brings in Great Customers

The heading is used—**466 million** references per year. Users tend to be middle aged males with lower education levels and moderate incomes:

- **64%** of users are age 25-49
- **59%** of users have high school education or less
- **56%** of users have incomes between \$25,000-\$60,000

Heading users frequently spend more on auto parts than the average customer.

(Statistical Research, Inc./Simmons, 2001).

five Recent

Yellow Pages are your last chance to affect a customer's decision. The last advertising impression has the greatest impact on consumer decisions.



9 Reasons Why You Need a Strong Yellow Pages Program

ANALYSIS BASED ON DATA FROM SRI, NFO COMMUNICATIONS AND SIMMONS.

Auto Parts & Supplies-New

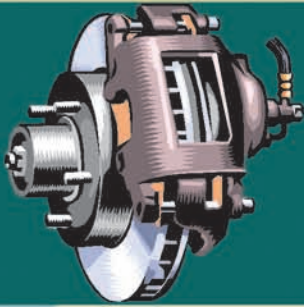

six | Good for Your Business

Yellow Pages bring in new customers—**31%** of purchases are from new customers. Yellow Pages bring revenues to your business—the average new auto parts display ad delivers over **\$200,000** in sales revenues from heading users.

(Statistical Research, Inc./CRM Associates, 2001).



seven | Great for Your Bottom Line

Yellow Pages are your best investment for growing profits! The typical new auto parts display ad generates **\$20** of sales revenue and over **\$8** of profit for every **\$1** spent on Yellow Pages.

(CRM Associates, 2001)



eight | Competitive

You pay less per customer for Yellow Pages than you pay for any other advertising medium. *(CRM, Associates, 2001).*

Cost Per Customer Influenced:

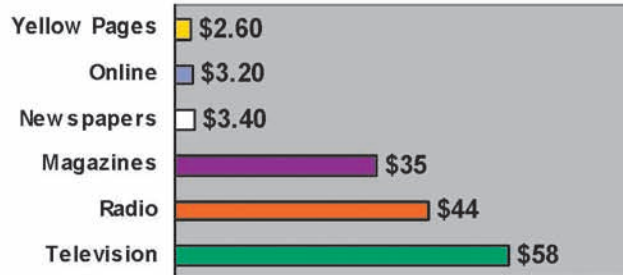

nine | Works Well with Other Media

Expands the reach of key media to active shoppers. Build brand and stimulate demand through other media—catch the consumer at purchase time through the Yellow Pages! Reach customers not reached through other media. *(NFO AD:impact).*

Chart shows how additional customers can be reached by adding Yellow Pages to your media mix

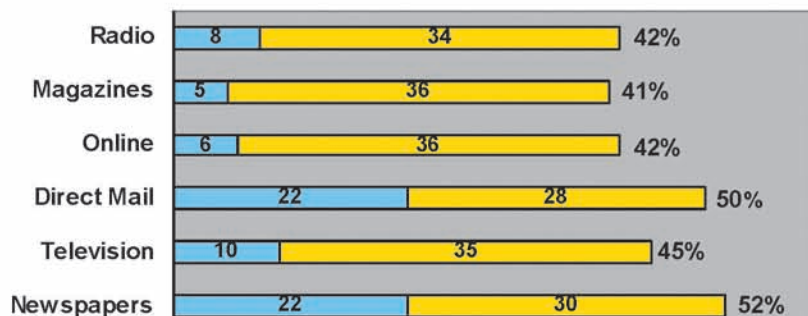

■ % of individuals who use the medium ■ Extended reach by adding Yellow Pages